



Technical Bulletin

2400 Boston Street, Suite 200, Baltimore, Maryland 21224

Phone: 410-675-2100 or 800-543-3840

Revised: 4/26/2018

DAP® '1012'® Window Glazing

- For face glazing metal window frames
- Forms an airtight, watertight seal
- Resists sagging, cracking and shrinking
- Meets ASTM C669 specification
- Needs no painting
- Interior/exterior use

Packaging: 1 gallon tub, 3.5 gallon tub
Colors: Aluminum Gray
UPC Numbers: 7079812059, 7079812056

Company Identification:

Manufacturer: DAP Products Inc., 2400 Boston Street, Baltimore, Maryland 21224
Usage Information: Call 888-DAP-TIPS or visit dap.com & click on "Ask the Expert"
Order Information: 800-327-3339 or orders@dap.com
Fax Number: 410-558-1068
Also, visit the DAP website at dap.com

Product Description:

DAP® '1012'® Window Glazing is a professional quality glazing compound that may be used for face glazing interior or exterior aluminum, primed steel, stainless steel and bonderized galvanized steel. Its knife grade consistency allows for smooth, easy application. DAP® '1012'® Window Glazing sticks tightly to glass and sash and resists sagging, cracking, shrinking, chalking, weathering and vibration.

Suggested Uses:

For face glazing metal window frames.

NOTE: Do not use DAP® '1012'® Glazing on wood sashes, plastic windowpanes, porcelainized steel insulating panels, insulated glass units with an organic seal, stained or leaded glass, any windowpane over 48 inches in any run direction, any metal rabbets over 1¼" wide, composite or composition panels, channel glazing or on any surfaces not prepared as set forth below.

Performance Characteristics:

DAP® '1012'® Window Glazing is for the back bedding and face glazing of metal sashes.

Surface Preparation, Application & Optional Painting:

Surface Preparation

1. When re-glazing, remove from sash (i) all old glazing compound, (ii) any spring clips, (iii) glass, and (iv) any back bedding. Glass should be free from any residual glazing compound and back bedding prior to reinstallation.
2. All surfaces should be clean, dry and free of frost or any substance that would compromise adhesion of the glazing material (e.g., wax, oil, grease, rust inhibitors, silicone residue, etc.).
3. Sash corners must be sealed. All sashes must be safely installed and adjusted prior to glazing and sufficiently rigid to permit normal operation without excessive bending or flexing. Adjustment of freshly glazed sash will disrupt the adhesive bond of the glazing material to the glass and sash.

Product Application

NOTE: Do not apply DAP® '1012'® Window Glazing when air or sash temperatures are below 40 °F or above 90 °F. Do not apply during damp or rainy weather or if rain is forecasted within 24 hours of application.

1. Mix entire contents of container by hand (by kneading or rolling glazing in gloved hands) until uniform. If the glazing compound is too stiff, the addition of a minimal amount of VM&P Naphtha Spirits only (not to exceed 1-1/2oz. for each one gallon of compound) will reduce the thickness. Do not add any type of oil, pigment or other thinners, solvents or additives to the glazing compound.
2. Bring compound to room temperature (68-72°F) prior to use. If necessary, place glazing in a gloved hand to warm and soften.
3. DAP® '1012'® Glazing must be applied to backstop of sash to provide back bedding where glass is to be set. Use spacer shims at quarter points to maintain 1/8" minimum bedding thickness throughout. Only DAP® '1012'® Glazing may be used for back bedding. There should be no metal frame-to-glass contact.
4. Press glass firmly into place. If glass size is over 24" in horizontal dimension, use setting blocks at quarter points on bottom rail. For clear glass, maintain 1/4" minimum contact area between glass and compound throughout. For heat absorbing glass, 3/8" minimum contact area is required throughout.
5. Install spring clips at quarter points of windowpane to hold glass, spacing them no more than 18" apart for exterior glazed sash. For interior glazed sash, space clips no more than 12" apart. Clips are necessary to hold the glass in place. The glazing compound should not be expected to perform this function.
6. Press only DAP® '1012'® Glazing onto sash and against glass, being careful to fill height and width of L-shaped recess completely.
7. Smooth glazing to an angle that sheds water. There should be no gaps, spaces or indentations. Then shape corners to a rounded finish only.
8. Remove excess glazing with mineral spirits before it sets.
9. If excess glazing needs to be removed after setting, such material must be cut, scraped away or otherwise mechanically removed.
10. Under most conditions, a firm set will be attained in 7-21 days depending on temperature, humidity, air movement, sunlight and fill volume. Firm set is typically demonstrated when a light finger touch to the surface does not leave a fingerprint. The drying time is approximately three weeks. The sash should be operated carefully to avoid possible adhesion loss. Full adhesion will develop within two to four months, depending on the job conditions.

Optional Product Painting

1. DAP® '1012'® Glazing does not require painting. However, if painting is desired, the glazing may be painted only after it has skinned over and attained a firm set.
2. When painting, use only (i) a high-quality, exterior-grade oil-based paint, or (ii) prime with a high quality oil-based primer and topcoat with a high quality exterior-grade acrylic-latex paint finish. The paint line must overlap onto the face portion of the glass, as well as the bedding area where the sash and glass meet.

NOTE: The glazing compound may still feel soft and may not have full adhesion even after it has skinned over and attained a firm set. Accordingly, sash should be operated carefully for approximately three weeks on the average. Glazing may still be damaged if sash is handled carelessly. Full adhesion will develop within two to four months, depending on job conditions.

Illustration of Key Terminology Used in Face Glazing

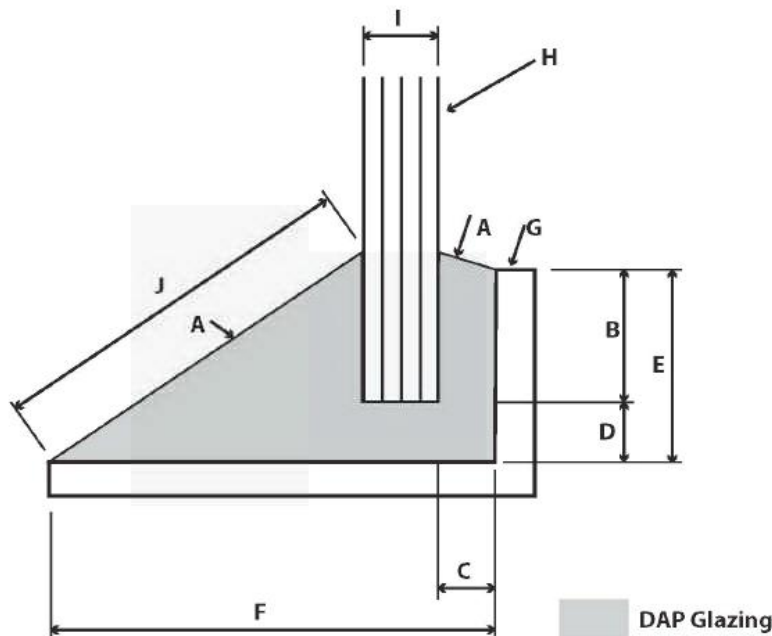

- A - Finish edge of glazing or sealing surface
- B - Bite (dimension by which the framing system overlaps the edge of the lite or glazing infill)
- C - Bed Thickness (minimum 1/8" required)
- D - Edge Clearance (the spacing between the edge of the lite & the bottom of the glazing pocket)
- E - Channel or Rabbet Depth
- F - Channel or Rabbet Width
- G - Fixed Stop (portion of the rabbet to receive glaze bedding & the edge of the lite or glazing infill)
- H - Lite (glass or panel)
- I - Lite Thickness
- J - Face Dimension

- NOTE 1: Setting blocks may be required depending on size of glass.
- NOTE 2: Spacer shims may be required depending on size of glass.
- NOTE 3: Metal spring clips required
- NOTE 4: Drawing is not to scale; for illustrative purposes only

Physical & Chemical Characteristics:

Time to Firm Set:	Approximately three weeks depending on temperature, humidity, air movement, sunlight and fill volume
Odor:	Mild
Consistency:	Knife Grade
Vehicle:	Oil and Rubber
Volatile:	Aliphatic Hydrocarbons
Filler:	Inorganic Fillers and Color Pigments
Solids:	Over 98% by weight
Weight per Gallon:	18.3 ± .2 pounds/per gallon
Temperature Service Range:	-20°F to 160°F
Temperature Application Range:	40°F (and rising) to 90°F (and falling)
Shelf Life:	12 Months in an unopened container stored at 68°-72°F or below
Coverage:	Varies by size of container; Call 1-888-DAP-TIPS for further information
SDS No.:	0010402001

Clean Up:

Clean tools immediately after use with mineral spirits. Dried material must be cut or scraped away. Do not use mineral spirits to clean skin. Be sure container lid is closed and tightly sealed. Store in a cool, dry place.

Safety:

See product label and Safety Data Sheet (SDS) for safety information. You can request an SDS by visiting our website at www.dap.com or by calling 1-888-DAP-TIPS.

Warranty Information:

DAP warrants this product, when applied in accordance with the requirements and directions set forth in DAP's label and technical bulletin, to be free from defects in materials, but makes no warranty as to appearance or color. Since methods of application and construction and environmental conditions are beyond DAP's control and could affect performance, DAP makes no other warranties, express or implied. With respect to this product, DAP's sole obligation shall be to supply replacement product, or to refund the purchase price, for that quantity of this product proved to be defective. DAP shall not be liable for any other losses or damages, including incidental or consequential damages. If a product defect is encountered, call DAP Products Inc., Technical Customer Service, at 888-DAP-TIPS for further information.